



User Manual

English

APC Smart-UPS® RT

7500/10000 VA 200-240 VAC 6U

Tower/Rack Mount

Uninterruptible Power Supply

990-1216A 12/2003

Introduction

The APC Smart-UPS RT is a high-performance, uninterruptible power system (UPS), designed to prevent blackouts, brownouts, sags and surges from reaching your computers, servers, and other sensitive electronic equipment.

1: INSTALLATION

Attention: Read the safety information sheet before installation.

Unpacking

Inspect the UPS upon receipt. Notify the carrier and dealer if there is damage.

The packaging is recyclable; save it for reuse or dispose of it properly.

Check the package contents:

- UPS (with batteries disconnected)
- Two front bezels
- Literature kit containing:
 - Software
 - Smart-UPS User Manuals CD
 - XLI model only*: Six output power cords
 - Serial cable
 - Product documentation, safety and warranty information
 - SNMP/Web Card User Manual

Removing the Batteries

The unit is heavy. To lighten the unit, remove the batteries. Refer to the unpacking instructions on the carton in which the unit is shipped.

Placement

Attention: The UPS is heavy. Select a location sturdy enough to handle the weight.

Do not operate the UPS in excessive dust or in temperature and humidity outside the specified limits.

Ensure the air vents on the front and rear of the UPS are not blocked.

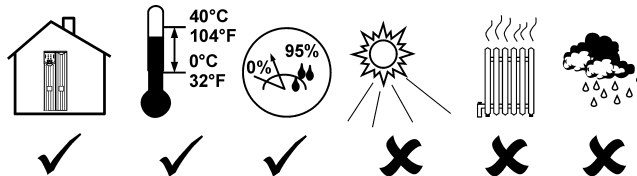

Refer to the APC web site, www.apc.com for details.





Hardwiring

Attention: Wiring must be performed by a qualified electrician.

1. Install a utility circuit breaker in accordance with local electrical codes (see tables below) for input wiring only.
2. Switch the UPS input circuit breaker (see **A**) and utility circuit breakers OFF.
3. Remove the access panel (see **B**).
4. Remove circular knockouts.
5. Run wires through access panel to terminal blocks. Wire to ground block first. **Adhere to all national and local electrical codes.** (See tables and graphics.)
6. Use appropriate glands to achieve strain-relief on the hardwired input and output power cables.

200/208V MODELS	
Input Connection	Output Connection (optional)
Wire to L1, L2, and  .	Wire to L1A, L2A, and  .

System	Wiring	Voltage	Current Full Load (Nominal)	External Input Circuit Breaker (typical)	Wire Size (typical)
SURT7500XLJ, SURT7500XLT	Input & Output	200/208V	40 amps	50 amps / 2-pole for Input Wiring Only	#8AWG/ 10mm ²
SURT10000XLJ, SURT10000XLT	Input & Output	200/208V	54 amps	70 amps / 2-pole for Input Wiring only	#6AWG/ 16mm ²

220/230/240V MODELS	
Input Connections	Output Connection (optional)
Single-Phase: Wire to L1, N, and  .	Wire to L1A, N1, and  .
Three-Phase: Wire to L1, L2, L3, N, and  .	

System	Wiring	Number of Phases	Voltage	Current Full Load (Nominal)	External Input Circuit Breaker (typical)	Wire Size (typical)
SURT7500XLI	Input	1	220/230/240V	38 amps	50 amps / 2-pole	10mm ²
	Input	3+ Neutral	380/400/415V	14 amps / phase when online, 38 amps on L1 in bypass	50 amps / 4-pole	10mm ²
	Output	1	220/230/240V	38 amps	(not required)	10mm ²
SURT10000XLI	Input	1	220/230/240V	50 amps	63 amps / 2-pole	16mm ²
	Input	3+ Neutral	380/400/415V	18 amps / phase when online, 50 amps on L1 in bypass	63 amps / 4-pole	16mm ²
	Output	1	220/230/240V	50 amps	(not required)	16mm ²

7. *230V model only*: For three-phase input, set the Input Phase Selector switch (see C) to '3'. For single-phase input, leave switch in default position of '1'.

XLT/XLJ MODELS (200/208V)

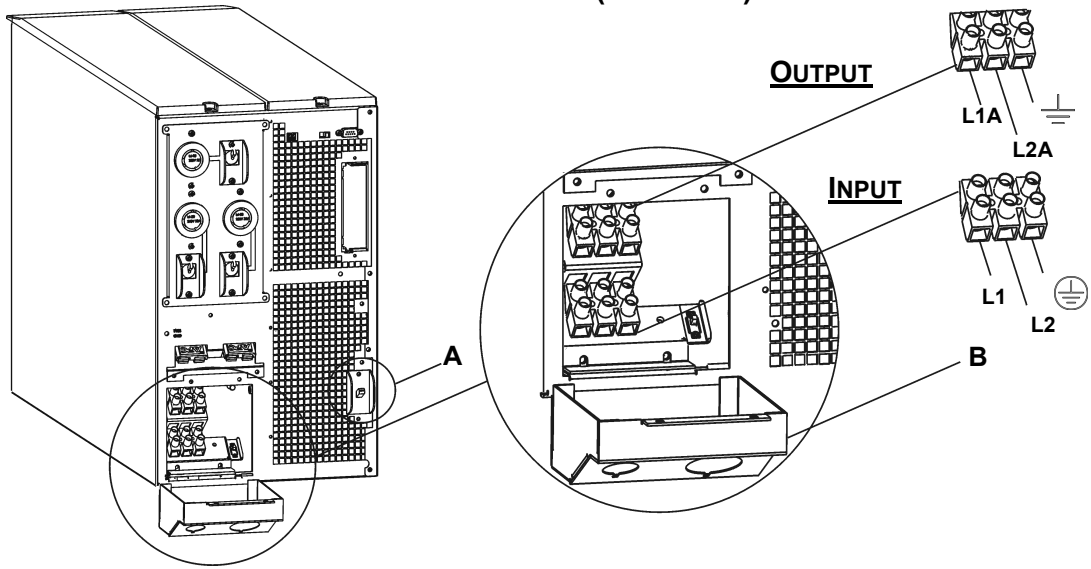

XLI MODEL (220/230/240V)

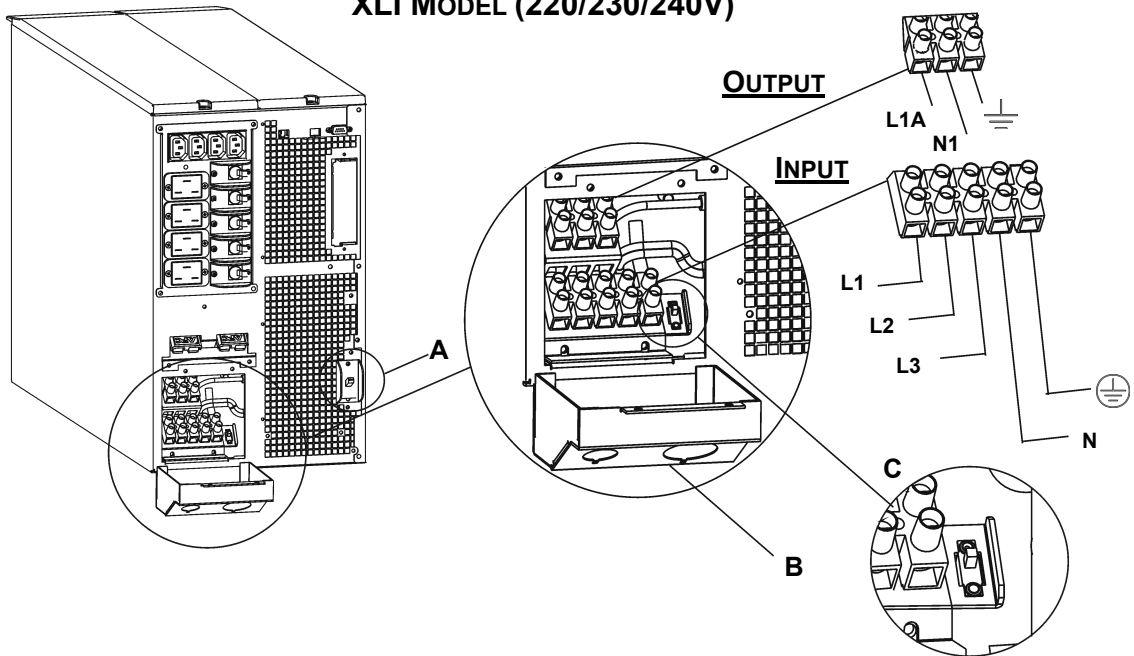

8. Switch the circuit breakers ON.
9. Check line voltages.
10. Replace the access panel.

Installing and Connecting the Batteries and Attaching the Front Bezel

1

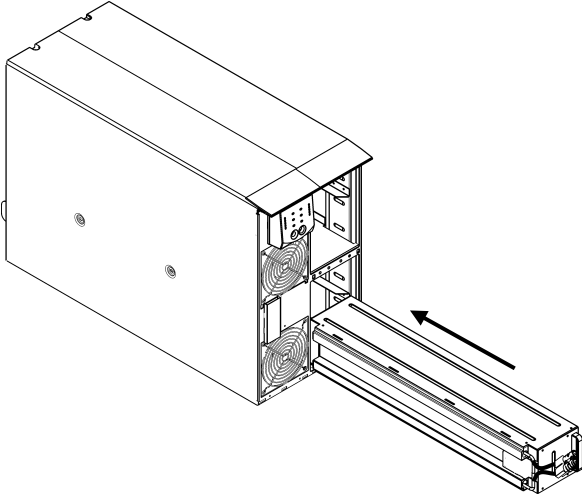

2

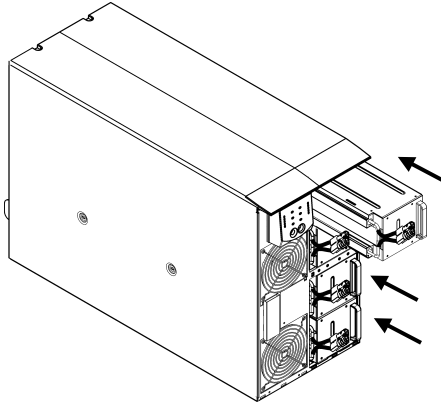

3

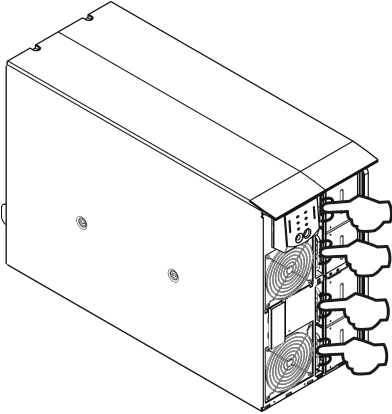

4

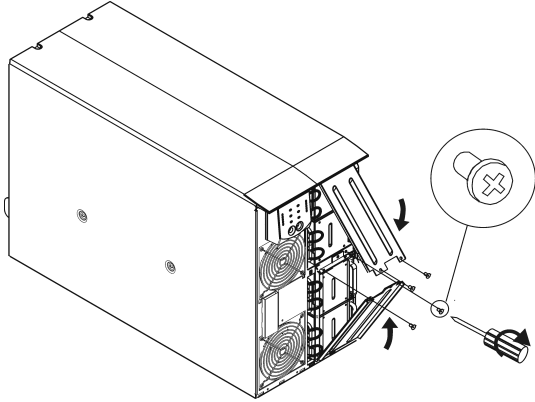

5

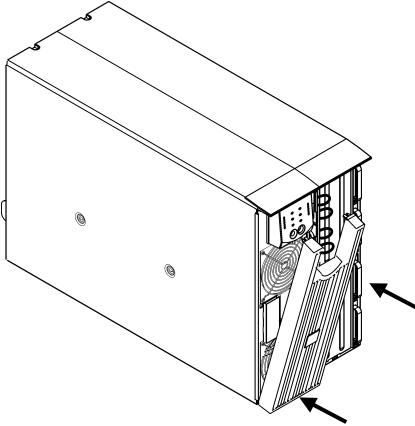

6

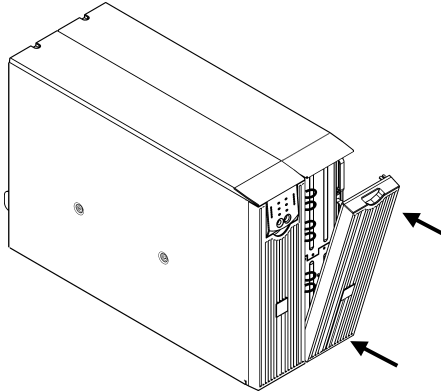

CONNECTING POWER AND EQUIPMENT TO THE UPS

1. Hardwire the UPS (see *Hardwiring*).
2. Connect equipment to the UPS (cables not included for XLT/XLJ models).
3. Turn on all connected equipment. To use the UPS as a master *on/off* switch, be sure that all connected equipment is switched ON.
4. Press the  button on the front panel to power up the UPS.
 - The battery charges to 90% capacity during the first three hours of normal operation. **Do not** expect full battery run capability during this initial charge period.
5. Configure the Web/SNMP management card (optional). See AP9617 instructions.





OPTIONS

Refer to the APC web site, www.apc.com for available accessories.

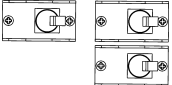
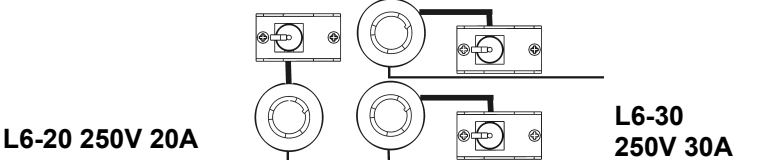
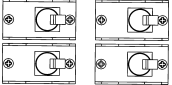
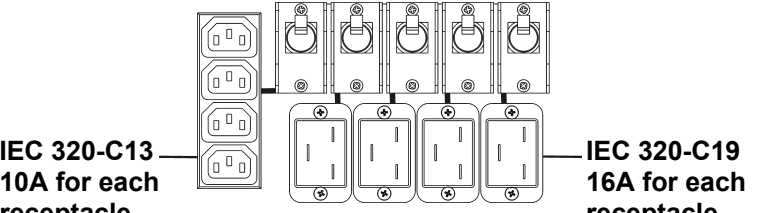
- External Battery Pack SURT192XLBP
- Rail Kit SURTRK2
- Isolation Transformer
- Service Bypass Panel

CIRCUIT BREAKERS

<p><i>Input Circuit Breaker</i> 7500/10000 VA XLI/XLJ/XLT</p> 	<p>The UPS is protected from extreme overloads when in ON position. The breaker must be on for the UPS to operate.</p>
<p><i>Output Circuit Breaker</i> 7500/10000 VA XLJ/XLT</p> 	 <p>L6-20 250V 20A L6-30 250V 30A</p>
<p><i>Output Circuit Breaker</i> 7500/10000 VA XLI</p> 	 <p>IEC 320-C13 10A for each receptacle IEC 320-C19 16A for each receptacle</p>

BASIC CONNECTORS	
 Serial Port	Power management software and interface kits can be used with the UPS. Use only interface kits supplied or approved by APC.
 Ethernet Port	Connect the UPS to the network. (Located on Web/SNMP card.)
 EPO Terminal	The optional Emergency Power Off (EPO) feature allows connected loads to be immediately de-energized from a remote location, without switching to battery operation (see <i>EPO Option</i>).
 TVSS Screw	The UPS features a transient voltage surge-suppression (TVSS) screw for connecting the ground lead on surge suppression devices such as telephone and network line protectors. When connecting grounding cable, disconnect the unit from the utility power outlet.
 External Battery Pack Connectors	Optional external battery packs provide extended runtime during power outages. These units support up to 10 external battery packs. See the APC website, www.apc.com/products for the information on the external battery pack, SURT192XLBP.





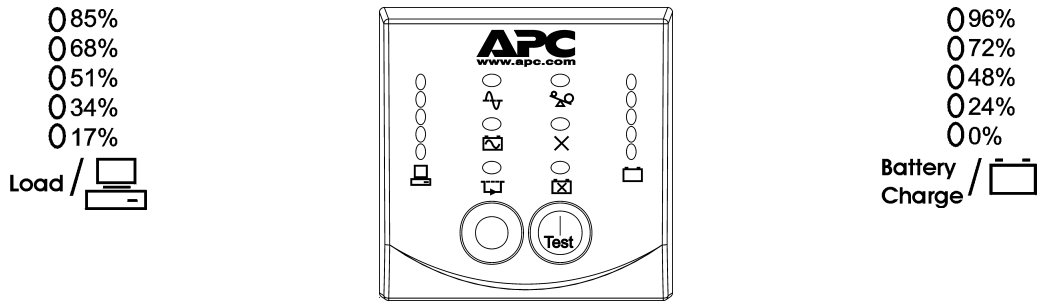

2: OPERATION

FRONT DISPLAY PANEL

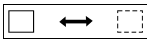

Indicator	Description
Online 	The UPS is drawing utility power and performing double conversion to supply power to connected equipment (see <i>Troubleshooting</i>).
On Battery 	The UPS is supplying battery power to the connected equipment.
Bypass 	The UPS is in bypass mode, sending utility power directly to connected equipment. Bypass mode operation is the result of an internal UPS fault, an overload condition or a user initiated command either through an accessory or the manual bypass switch. Battery operation is not available while the UPS is in bypass mode (see <i>Troubleshooting</i>).
Fault 	The UPS detects an internal fault (see <i>Troubleshooting</i>).
Overload 	The connected loads are drawing more power than the UPS power rating (see <i>Troubleshooting</i>).
Replace Battery 	The battery is disconnected or must be replaced (see <i>Troubleshooting</i>).

Feature	Function
Power On 	Press this button to turn on the UPS. (Read on for additional capabilities.)
Power Off 	Press this button to turn off the UPS.

Feature	Function																														
Normal /Bypass 	Manually switch connected equipment to bypass mode, so that utility power is sent directly to connected equipment. Battery operation is not available while the UPS is in bypass mode. (See <i>Troubleshooting</i> .)																														
Cold Start	This is not a normal condition. Supply immediate battery power to the UPS and connected equipment (see <i>Troubleshooting</i>). Press and hold the  button to power up the UPS and connected equipment. The UPS will emit two beeps. During the second beep, release the button.																														
Self-Test	<p>Automatic: The UPS performs a self-test automatically when turned on, and every two weeks thereafter (by default). During the self-test, the UPS briefly operates the connected equipment on battery.</p> <p>Manual: Press and hold the  button for a few seconds to initiate the self-test.</p>																														
Diagnostic Utility Voltage <table border="0"> <tr> <td>200V</td> <td>208V</td> <td>220V</td> </tr> <tr> <td>0 236</td> <td>0 245</td> <td>0 256</td> </tr> <tr> <td>0 217</td> <td>0 226</td> <td>0 238</td> </tr> <tr> <td>0 199</td> <td>0 207</td> <td>0 219</td> </tr> <tr> <td>0 180</td> <td>0 189</td> <td>0 200</td> </tr> <tr> <td>0 161</td> <td>0 170</td> <td>0 181</td> </tr> </table>  <table border="0"> <tr> <td>230V</td> <td>240V</td> </tr> <tr> <td>0 266</td> <td>0 276</td> </tr> <tr> <td>0 248</td> <td>0 258</td> </tr> <tr> <td>0 229</td> <td>0 239</td> </tr> <tr> <td>0 210</td> <td>0 220</td> </tr> <tr> <td>0 192</td> <td>0 202</td> </tr> </table> 	200V	208V	220V	0 236	0 245	0 256	0 217	0 226	0 238	0 199	0 207	0 219	0 180	0 189	0 200	0 161	0 170	0 181	230V	240V	0 266	0 276	0 248	0 258	0 229	0 239	0 210	0 220	0 192	0 202	The UPS has a diagnostic feature that displays the utility voltage. Plug the UPS into the normal utility power. <p>The UPS starts a self-test as part of this procedure. The self-test does not affect the voltage display.</p> Press and hold the  button to view the utility voltage bar graph display. After a few seconds the five-LED, <i>Battery Charge</i>  display on the right of the front panel shows the utility input voltage. Refer to the figure at left for the voltage reading (values are not listed on the UPS). The display indicates the voltage is between the displayed value on the list and the next higher value.
200V	208V	220V																													
0 236	0 245	0 256																													
0 217	0 226	0 238																													
0 199	0 207	0 219																													
0 180	0 189	0 200																													
0 161	0 170	0 181																													
230V	240V																														
0 266	0 276																														
0 248	0 258																														
0 229	0 239																														
0 210	0 220																														
0 192	0 202																														

On Battery Operation

The UPS switches to battery operation automatically if the utility power fails. While running on battery, an alarm beeps four times every 30 seconds.

Press the  button to silence this alarm. If the utility power does not return, the UPS continues to supply power to the connected equipment until the battery is fully discharged.

When two minutes of runtime remain the UPS emits a continuous beep. If PowerChute or the Web/SNMP card is not being used, files must be manually saved and the computer must be properly shut down before the UPS fully discharges the battery.

The UPS battery life differs based on usage and environment. Refer to www.apc.com/products for on battery runtimes.

3: USER CONFIGURABLE ITEMS

NOTE: SETTINGS ARE MADE THROUGH SUPPLIED POWERCHUTE SOFTWARE, WEB/SNMP CARD, OPTIONAL SMART SLOT ACCESSORY CARDS OR TERMINAL MODE.			
<i>FUNCTION</i>	<i>FACTORY DEFAULT</i>	<i>USER SELECTABLE CHOICES</i>	<i>DESCRIPTION</i>
Automatic Self-Test	Every 14 days (336 hours)	Every 7 days (168 hours), Every 14 days (336 hours), On Startup Only, No Self-Test	Set the interval at which the UPS will execute a self-test.
UPS ID	UPS_IDEN	Up to eight characters to define the UPS	Uniquely identify the UPS, (i.e. server name or location) for network management purposes.
Date of Last Battery Replacement	Manufacture Date	mm/dd/yy	Reset this date when you replace the battery modules.
Minimum Capacity Before Return from Shutdown	0 percent	0, 15, 25, 35, 50, 60, 75, 90 percent	Specify the percentage to which batteries will be charged following a low-battery shutdown before powering connected equipment.
Alarm Delay After Line Failure	5 second delay	5 second delay, 30 second delay, At Low Battery, Never	Mute ongoing alarms or disable all alarms permanently.
Shutdown Delay	20 seconds	0, 20, 60, 120, 240, 480, 720, 960 seconds	Set the interval between the time when the UPS receives a shutdown command and the actual shutdown.
Duration of Low Battery Warning.	2 minutes PowerChute software provides automatic, unattended shutdown when approximately two minutes of battery runtime remains.	2, 5, 7, 10, 12, 15, 18, 20 minutes.	The low battery warning beeps become continuous when two minutes of runtime remains. Change the warning interval to a higher setting if the operating system requires a longer interval for shutdown.
Synchronized Turn-on Delay	0 seconds	0, 20, 60, 120, 240, 480, 720, 960 seconds	Specify the time the UPS will wait after the return of utility power before turn-on (to avoid branch circuit overloads).

NOTE: SETTINGS ARE MADE THROUGH SUPPLIED POWERCHUTE SOFTWARE, WEB/SNMP CARD, OPTIONAL SMART SLOT ACCESSORY CARDS OR TERMINAL MODE.

FUNCTION	FACTORY DEFAULT	USER SELECTABLE CHOICES	DESCRIPTION
High Bypass Point	+10% of output voltage setting	+5%, +10%, +15%, +20%	Maximum voltage that the UPS will pass to connected equipment during internal bypass operation.
Low Bypass Point	-30% of output voltage setting	-15%, -20%, -25%, -30%	Minimum voltage that the UPS will pass to connected equipment during internal bypass operation.
Output Voltage	200 V models: 200 VAC 208 V models: 208 VAC 230 V models: 230 VAC	200 V models: 200VAC 208 V models: 200, 208, 220, 230, 240 VAC 230 V models: 200, 208, 220, 230, 240 VAC *Use the voltage setting applicable to your region.	Allows the user to select the UPS output voltage while online.
Output Frequency	Automatic (50 ± 3 Hz or 60 ± 3 Hz)	50 ± 3 Hz, 50 ± 0.1 Hz, 60 ± 3 Hz, 60 ± 0.1 Hz	Sets the allowable UPS output frequency. Whenever possible, the output frequency tracks the input frequency.
Number of Battery Packs	1	Number of Connected Batteries (four battery modules per pack)	Defines the number of connected battery packs for proper runtime prediction.

EPO (Emergency Power Off) Option

The output power can be disabled in an emergency by closing a switch connected to the EPO.

Adhere to national and local electrical codes when wiring.

The switch should be connected in a normally open switch contact. External voltage is not required; the switch is driven by 12V internal supply. In closed condition, 2mA of current are drawn.

The EPO switch is internally powered by the UPS for use with non-powered switch circuit breakers.

The EPO circuit is considered a Class 2 circuit, (UL, CSA standards) and an SELV circuit (IEC standard).

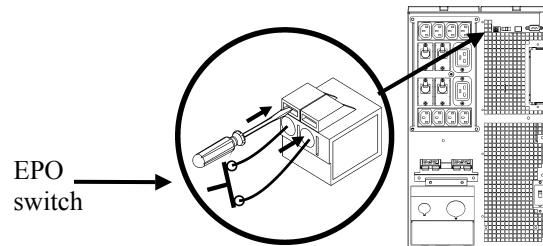

Both Class 2 and SELV circuits must be isolated from all primary circuitry. Do not connect any circuit to the EPO terminal block unless it can be confirmed that the circuit is Class 2 or SELV. If circuit standard cannot be confirmed, use a contact closure switch.

Use one of the following cable types to connect the UPS to the EPO switch:

- CL2: Class 2 cable for general use
- CL2P: Plenum cable for use in ducts, plenums, and other spaces used for environmental air.
- CL2R: Riser cable for use in a vertical run in a floor-to-floor shaft.
- CLEX: Limited use cable for use in dwellings and for use in raceways.
- For installation in Canada: Use only CSA certified, type ELC (extra-low voltage control cable).
- For installation in other countries: Use standard low-voltage cable in accordance with local regulations.

Terminal Mode to Configure UPS Parameters

Terminal Mode is a menu driven interface that enables enhanced configuration of the UPS.

Connect the serial cable to the serial port on the back of the UPS.

When using PowerChute® *Network Shutdown* software:

1. Open a terminal program. Example: HyperTerminal
 - From the Desktop, go to **Start => Programs => Accessories => Communication =>HyperTerminal.**
2. Double-click on the **HyperTerminal** icon.
 - Follow the prompts to choose a name and select an icon. Disregard the message, "...must install a modem," if it is displayed. Click OK.
 - Select the **COM** port that is connected to your UPS. The port settings are:
 - ✓ *bits per second - 2400*
 - ✓ *data - bits 8*
 - ✓ *parity - none*
 - ✓ *stop bit - 1*
 - ✓ *flow control - none*
 - Click Enter
3. Example for setting the number of external battery packs (SURT192XLBP):

Once the blank terminal window is open, follow these steps to enter the number of battery packs:

 - Press ENTER to initiate terminal mode. Press ENTER multiple times, until the prompt **User Name:** is displayed. Follow the prompts. Type slowly, waiting until each character appears on the screen prior to typing the next character.

Web/SNMP Card defaults:

 - User Name: apc
 - Password: apc
 - Press 1 and ENTER to select Device Manager.
 - Select the model by entering the corresponding number, then press ENTER.
 - Press 3 and ENTER to select Configuration.
 - Press 1 and ENTER to select Battery.
 - Press 2 and ENTER to change the Battery Settings.
 - Type in the number of external battery packs (four battery modules per pack), then press ENTER. (Number of packs: 1= internal battery module, 2 = 1 SURT192XLBP, 3 = 2 SURT192XLBP, etc.)
 - Press 3 and ENTER to accept the changes.
 - Press ESC multiple times (5) to return to the main menu.
 - Press 4 and ENTER to log out.

4: STORAGE, MAINTENANCE, AND TRANSPORTING

Storage

Store the UPS covered and positioned as for proper functioning, in a cool, dry location, with the batteries fully charged. (Batteries must be charged every six months.)

Store at: 0-50,000 ft (0 - 15,000 m)
5°-113° F (-15 - 45 ° C)

Replacing the Battery Module(s)

This UPS has easy to replace, hot-swappable battery modules. Replacement is a safe procedure, isolated from electrical hazards. You may leave the UPS and connected equipment on during the procedure. See your dealer or contact APC at the web site, www.apc.com for information on replacement battery modules.

The battery replacement procedure must include replacing all battery modules in the UPS and connected external battery pack (s).

Upon battery disconnection, equipment is not protected from power outages.

Use caution when handling heavy battery modules.

Refer to *Installing and Connecting the Batteries and Attaching the Front Bezel* for battery replacement procedure; reverse instructions for battery removal.



Be sure to deliver the spent battery to a recycling facility or ship it to APC in the replacement battery packing material.

Transporting the UPS

Always disconnect the battery module(s) before shipping the UPS in compliance with U.S. Department of Transportation (DOT) regulations.





The battery module(s) may remain in the UPS.

1. Shut down and disconnect any equipment attached to the UPS.
2. Shut down and disconnect the UPS from the power supply.
3. Unplug the battery connectors.

For shipping instructions contact APC at the web site, www.apc.com/support/contact.

5: TROUBLESHOOTING

Use the table below to solve minor installation and operation problems. Refer to the APC web site, www.apc.com, for assistance with complex UPS problems.

PROBLEM AND POSSIBLE CAUSE	SOLUTION
UPS WILL NOT TURN ON	
Batteries are not connected properly.  button not pushed. UPS not connected to utility power supply. Very low or no utility voltage.	Check that the battery connectors are fully engaged. Press the  button once to power the UPS and the connected equipment. Check that the power cable from the UPS to the utility power supply is securely connected at both ends. Check the utility power supply to ensure proper voltage at the receptacle.
UPS WILL NOT TURN OFF	
 button not pushed. Internal UPS fault.	Press the  button once to turn the UPS off. Do not attempt to use the UPS. Unplug the UPS and have it serviced immediately.
UPS BEEPS OCCASIONALLY	
Normal UPS operation when running on battery.	None. The UPS is protecting the connected equipment.
UPS DOES NOT PROVIDE EXPECTED BACKUP TIME	
The UPS battery module(s) are weak due to a recent outage or are near the end of service life.	Charge the battery module(s). Modules require recharging after extended outages and wear faster when put into service often or when operated at elevated temperatures. If the battery module(s) are near the end of service life, consider replacing, even if the <i>Replace Battery</i> LED is not illuminated.
FRONT PANEL LEDs FLASH SEQUENTIALLY	
The UPS has been shut down remotely through software or an optional accessory card.	None. The UPS will restart automatically when utility power returns.
ALL LEDs ARE OFF AND THE UPS IS CONNECTED TO UTILITY POWER	
The UPS is shut down and the battery is discharged from an extended outage.	None. The UPS will return to normal operation when the power is restored and the battery has a sufficient charge.
BYPASS AND OVERLOAD LEDs ILLUMINATE, UPS EMITS A SUSTAINED ALARM TONE	
The UPS is overloaded.	The connected equipment exceeds the specified “maximum load” as defined in <i>Specifications</i> on the APC web site, www.apc.com . The alarm remains on until the overload is removed. Disconnect nonessential equipment from the UPS to eliminate the overload condition.

PROBLEM AND POSSIBLE CAUSE	SOLUTION
BYPASS LED ILLUMINATES	
The bypass switch has been turned on manually or through an accessory.	If bypass is the chosen mode of operation, ignore the illuminated LED. If bypass is not the chosen mode of operation move the bypass switch on the back of the UPS, to the <i>normal</i> position.
FAULT AND OVERLOAD LEDS ILLUMINATE; UPS EMITS A SUSTAINED ALARM TONE	
The UPS has ceased sending power to connected equipment.	The connected equipment exceeds the specified “maximum load” as defined in <i>Specifications</i> on the APC web site, www.apc.com . Disconnect nonessential equipment from the UPS to eliminate the overload condition. Press the OFF button, then the ON button to restore power to connected equipment.
FAULT LED ILLUMINATES	
Internal UPS fault.	Do not attempt to use the UPS. Turn the UPS off and have it serviced immediately.
REPLACE BATTERY LED ILLUMINATES	
<i>Replace Battery</i> LED flashes and a short beep is emitted every two seconds to indicate the battery is disconnected.	Check that the battery connectors are fully engaged.
Weak battery.	Allow the battery to recharge for 24 hours. Then, perform a self-test. If the problem persists after recharging, replace the battery.
Failure of a battery self-test.	The UPS emits short beeps for one minute and the <i>Replace Battery</i> LED illuminates. The UPS repeats the alarm every five hours. Perform the self-test procedure after the battery has charged for 24 hours to confirm the <i>Replace Battery</i> condition. The alarm stops and the LED clears if the battery passes the self-test.
UPS OPERATES ON BATTERY ALTHOUGH LINE VOLTAGE EXISTS	
Very high, low, or distorted line voltage. (Inexpensive fuel powered generators can distort the voltage.)	Move the UPS to a different line circuit. Test the input voltage with the utility voltage display.
DIAGNOSTIC UTILITY VOLTAGE	
All five LEDs are illuminated.	The line voltage is extremely high and should be checked by an electrician.
There is no LED illumination.	If the UPS is plugged into a properly functioning utility power outlet, the line voltage is extremely low.
ONLINE LED	
There is no LED illumination.	The UPS is running on battery, or it is not turned on.
The LED is blinking.	The UPS is running an internal self-test.

Service

If the UPS requires service do not return it to the dealer. Instead, follow these steps:

1. Review the problems discussed in the *Troubleshooting* section of this manual to eliminate common problems.
2. If the problem persists, contact APC Customer Service through the APC web site, www.apc.com/support.
 - Note the model number of the UPS, the serial number, and the date purchased. If you call APC Customer Service, a technician will ask you to describe the problem and try to solve it over the phone, if possible. If this is not possible, the technician will issue a Returned Material Authorization Number (RMA#).
 - If the UPS is under warranty, repairs are free. If not, there is a repair charge.
3. Pack the UPS in its original packaging. If the original packing is not available, refer to the APC web site, www.apc.com/support, for information about obtaining a new set.
 - Pack the UPS properly to avoid damage in transit. Never use Styrofoam beads for packaging. Damage sustained in transit is not covered under warranty.
 - **Always disconnect the battery module(s) before shipping in compliance with U.S. Department of Transportation (DOT) regulations.**
The battery module(s) may remain in the UPS.
4. Mark the RMA# on the outside of the package.
5. Return the UPS by insured, prepaid carrier to the address given to you by Customer Service.

Contacting APC

In the USA: Refer to the APC web site, www.apc.com/support.

Outside the USA: Refer to the APC web site, www.apc.com. Select the appropriate country from the country selection field. Select the *Support* tab at the top of the web page.

6: REGULATORY AND WARRANTY INFORMATION

Regulatory Agency Approvals and Radio Frequency Warnings

200, 208, 220, 230, 240 V MODELS

This is a Class A product. In a domestic environment this product may cause radio interference, in which case the user may be required to take corrective actions.

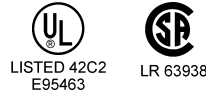

This equipment has been tested and found to comply with the limits for a Class A digital device, pursuant to part 15 of the FCC Rules. These limits are designed to provide reasonable protection against harmful interference when the equipment is operated in a commercial environment. This equipment generates, uses, and can radiate radio frequency energy and, if not installed and used in accordance with the instruction manual, may cause harmful interference to radio communications. Operation of this equipment in a residential area is likely to cause harmful interference. The user is responsible for correcting the interference.

Shielded signal cables must be used with this product to ensure compliance with the Class A FCC limits.



この装置は、情報処理装置等電波障害自主規制協議会（VCCI）の基準に基づくクラス A 情報技術装置です。この装置を家庭環境で使用すると電波妨害を引き起こすことがあります。この場合には使用者が適切な対策を講ずるよう要求されることがあります。



Declaration of Conformity

2003

Date of product declaration

CE Declaration of Conformity

We, the undersigned, declare under our sole responsibility that the equipment specified below conforms to the following standards and directives:

Standards to Which Conformity Declared:	EN 50091-1, EN 55022, EN 50082-1, EN 60950, IEC 950
Application of Council Directives:	73/23/EEC, 89/336/EEC, 91/157/EEC, 92/31/EEC, 93/68/EEC
Type of Equipment:	Uninterruptible Power Supply
Model Numbers:	SURT7500XLI, SURT10000XLI
Manufacturer's Name and Address:	American Power Conversion 132 Fairgrounds Road West Kingston, Rhode Island, 02892, USA -or- American Power Conversion (A. P. C.) b. v. Ballybritt Business Park Galway, Ireland -or- American Power Conversion Lot 10, Blk 16 PEZA Rosario, Cavite Philippines -or- American Power Conversion 2nd Street PEZA Cavite Economic Zone Rosario, Cavite Philippines -or- American Power Conversion Lot 3, Blk 14 PEZA Rosario, Cavite Philippines -or- APC (Suzhou) UPS Co., Ltd 339 Suhong Zhong Lu Suzhou Industrial Park Suzhou Jiangsu 215021 P R China
Importer's Name and Address:	American Power Conversion (A. P. C.) b. v. Ballybritt Business Park Galway, Ireland
Place:	N. Billerica, MA U.S.A. Richard J. Everett, 18 Apr 03 Sr. Regulatory Compliance Engineer 
Place:	Galway, Ireland Ray S. Ballard, 18 Apr 03 Managing Director, Europe 

Limited Warranty

American Power Conversion (APC) warrants its products to be free from defects in materials and workmanship for a period of two years from the date of purchase. Its obligation under this warranty is limited to repairing or replacing, at its own sole option, any such defective products. To obtain service under warranty you must obtain a Returned Material Authorization (RMA) number from customer support. Products must be returned with transportation charges prepaid and must be accompanied by a brief description of the problem encountered and proof of date and place of purchase. This warranty does not apply to equipment that has been damaged by accident, negligence, or misapplication or has been altered or modified in any way. This warranty applies only to the original purchaser who must have properly registered the product within 10 days of purchase.

EXCEPT AS PROVIDED HEREIN, AMERICAN POWER CONVERSION MAKES NO WARRANTIES, EXPRESSED OR IMPLIED, INCLUDING WARRANTIES OF MERCHANTABILITY AND FITNESS FOR A PARTICULAR PURPOSE. Some states do not permit limitation or exclusion of implied warranties; therefore, the aforesaid limitation(s) or exclusion(s) may not apply to the purchaser. EXCEPT AS PROVIDED ABOVE, IN NO EVENT WILL APC BE LIABLE FOR DIRECT, INDIRECT, SPECIAL, INCIDENTAL, OR CONSEQUENTIAL DAMAGES ARISING OUT OF THE USE OF THIS PRODUCT, EVEN IF ADVISED OF THE POSSIBILITY OF SUCH DAMAGE. Specifically, APC is not liable for any costs, such as lost profits or revenue, loss of equipment, loss of use of equipment, loss of software, loss of data, costs of substitutes, claims by third parties, or otherwise.

Entire contents copyright © 2003 by American Power Conversion Corporation. All rights reserved.
Reproduction in whole or in part without permission is prohibited.

APC, Smart-UPS, and PowerChute are registered trademarks of American Power Conversion Corporation. All other trademarks are the property of their respective owners.